

# Anlagentechnik

---

## Core Residue Recycling Unit



**Kurzer Morgen 2  
D-58239 Schwerte  
Germany**

**Tel.: +49 (0)2304 91118-0  
Fax: +49 (0)2304 91118-29  
info@Klann-Anlagentechnik.de  
www.Klann-Anlagentechnik.de**



During core fabrication, handling or placement into cast forms can destroy up to 10 % of the core quantity. Unlike the core residues after casting, the binder content of the core fraction is not thermally destroyed, remaining in its original chemical form. If amine-based binder processes are used, the core fractions/residues require costly disposal. By processing and recycling these core residue cost reductions are realized not only in raw material, but in disposal and transport costs as well.

Core residues can be processed within the cast shop with limited space required. The recycling machinery consists of the following distinct components:

- A vibration trough for grinding agglomerates and impurity separation;
- A filter station for de-dusting and separation of the dust fraction in recycled core sand;
- A pneumatic sender for compressed air transport of the recycled sand to a silo;
- A recycled sand storage silo with a dosing/discharge mechanism for the core sand mixing station.



Pic.1: view into the vibrating trough with the core fraction to be recycled

The core fractions/residues are fed by transport belt or directly by emptying collection containers into the vibration trough. The trough is equipped with motors on each side which serve to vibrate the inserted material. The core pieces are crushed by the surface structure of the trough as well as the grinding of the pieces against one another. The result of this process is a finer material which descends through holes in the trough bottom on to the guide plates where they flow in cascades upon the screen decks. While cascading, dust is separated by air flow from the filter station and collected in the filter bin. On the vibrating screen deck small agglomerates are again stressed mechanically and broken into smaller grains. Grains larger than 1 mm in diameter are considered impurities and are discharged through a pipe on one side of the trough. Those less than 1 mm are guided to the bottom of the trough and are considered recycled sand. A special pneumatic sender below the trough

collects this sand and, using low pressure (1.5 bar), blows it smoothly into the silo.

Once in the silo, the recycled sand can be used in the core sand binder mixing plant. Depending on the core binder process, up to 10 % of raw sand can be replaced with this recycled sand.

The recycling system is designed not only for the processing of amine-based cores but for Cold-Box and CO<sub>2</sub>-processed cores as well.

The recycling unit is available in two sizes:

	RT 700	RT 1000
Outer dimensions (W x D x H)	1,400 x 1,300 1,400 mm	1,800 x 1,700 x 1,600 mm
Trough opening	700 x 700 mm	1,000 x 1,000 mm
Vibration drives	2 x 0.75 kW	2 x 1.5 kW
Capacity	500–700 kg/hr.	800-1,200 kg/hr.
Required. air flow.	900 m <sup>3</sup> /hr.	1,500 m <sup>3</sup> /hr

The separated core fractions are:

- coarse fraction: > 1 mm, larger pieces removed directly from the trough or automatically discharged through a side pipe;
- recycled sand: < 1mm, discharged in the bottom middle of the trough;
- dust: by filter ventilation



Pic.2: vibration trough RT 700 in a foundry

The machinery, including controls, are designed for fully-automated 24/7 operation as well as for manual batch operations. The high-quality, maintenance-free, vibration motors and the easy accessible screen decks, facilitating easy inspection and maintenance, ensure maximum reliability.

The machinery has proven itself in various applications over the last 15 years, demonstrating its feasibility for use in core shops.

These core recycling systems are supplied to the casting industry by KLANN worldwide as a part of new turn-key core shops, as retrofit in existing core shops, or as individual equipment.

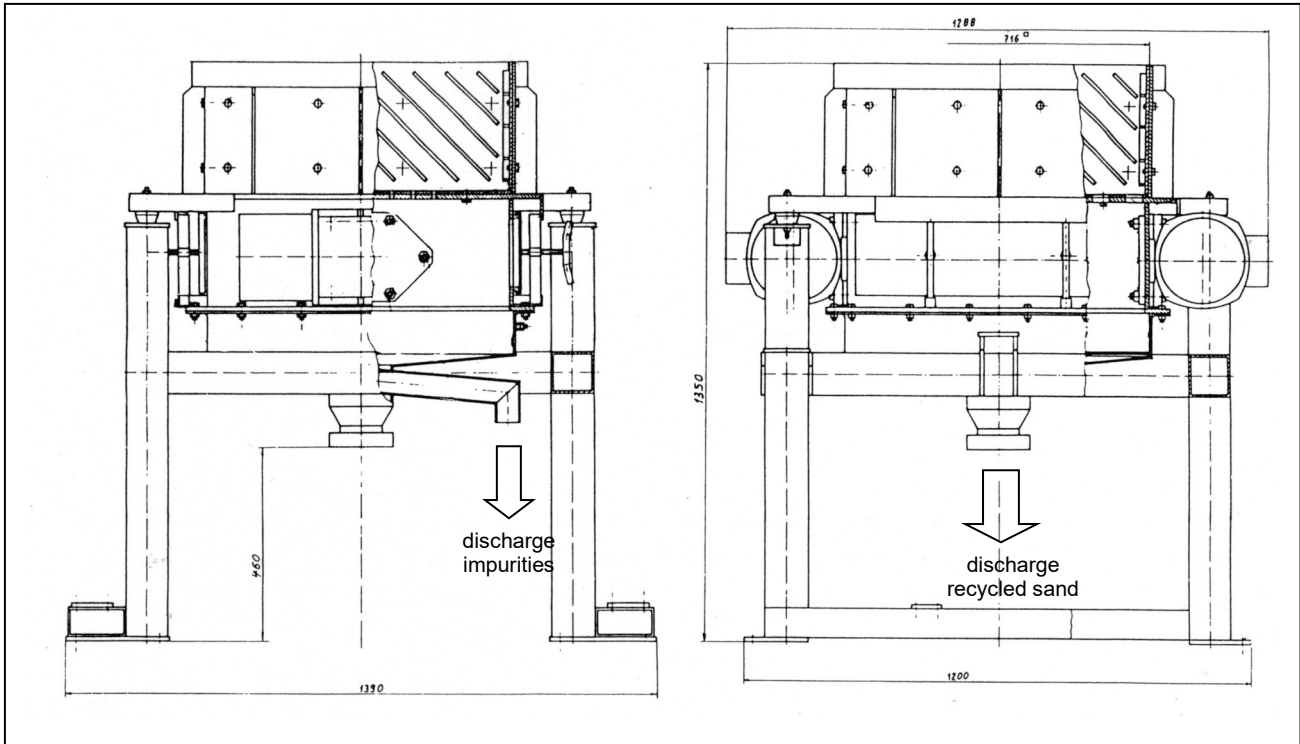

Sketch: dimensions of the KLANN vibration trough RT 700 for core residue recycling

Also available for cast shops from **KLANN Anlagentechnik**:

- Turn-key core shops
- Core shooters
- Core belters
- Core sand mixers and preparation plants
- Hoist gears for core sand transport
- Binder dosing systems
- Drum and container storage facilities for binders
- Silo storage- and dosing systems
- Sand dedusters and cooler
- Pneumatic conveyors
- Automation and Control Systems
- Handling systems/robots for cores